

DRAWING

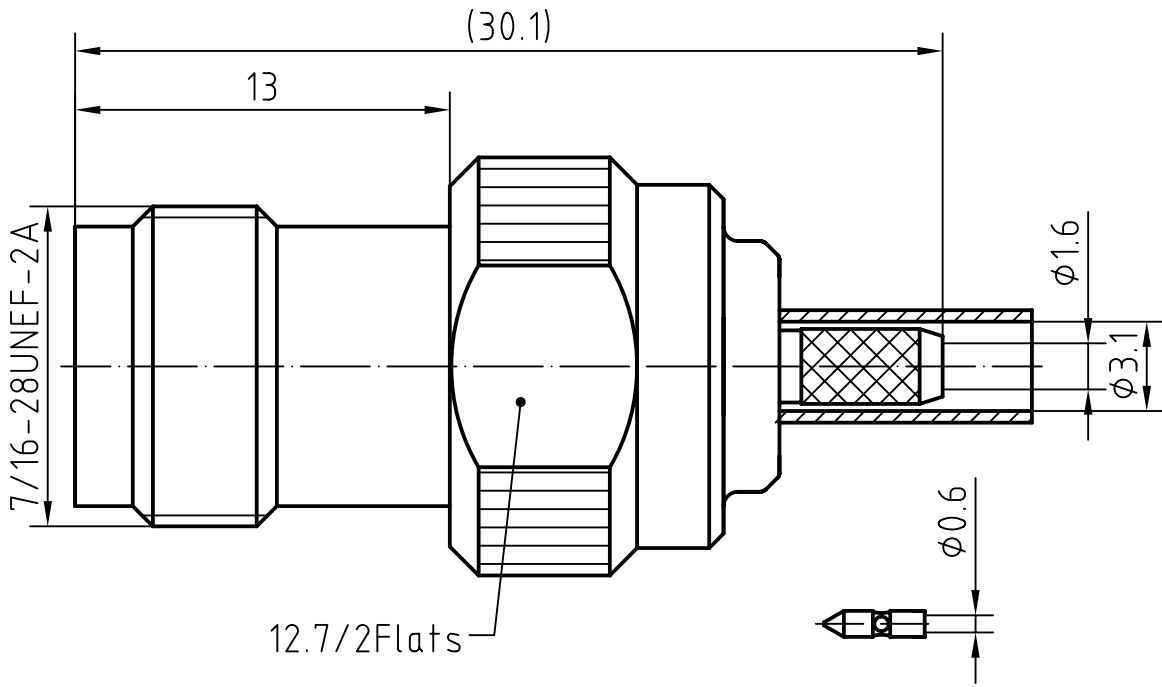

CABLE(RG174A/U, RG188A/U, RG316/U)

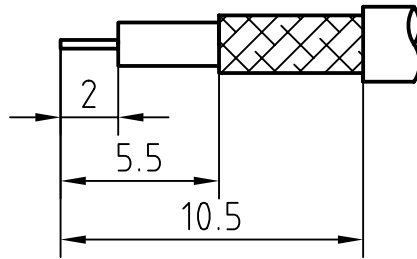

3	1	Body	Brass/Nickel plated	Nickel 5um over Copper 2um
2	1	Insulator	PTFE	
1	1	Center contact	Phosphor bronze/Gold plated	Gold 0.2um over Nickel 2um
Itemref	Quantity	Title/Name, designation, material, dimension etc		Article No./Reference

Designed by Mingang Han	Checked by Jinlong GU	Approved by - date Hongyu Du	File name TNC-K3Y	Date 08.02.12	Scale 4 : 1
----------------------------	--------------------------	---------------------------------	----------------------	------------------	----------------

Amitron Electronics, Ltd.	TNC-K3Y			
	<a href="http://www.amel.ru">http://www.amel.ru</a>	Edition 1.0	Sheet 1/1	

## CHARACTERISTICS

DESCRIPTION: TNC Type female connector

### Electrical data:

<i>Impedance:</i>	50 ohm
<i>Frequency range:</i>	DC to 10 GHz
<i>VSWR:</i>	$\leq 1.08 + 0.025Xf[\text{GHz}]$
<i>Insertion loss:</i>	$\leq 0.08X \sqrt{f[\text{GHz}]} \text{ dB}$
<i>Insulation resistance:</i>	$\geq 5000\text{M}\Omega$
<i>Test voltage:</i>	1500 V rms
<i>Working voltage:</i>	500 V rms
<i>Contact resistance:</i>	
1). Centre contact:	1.5 m $\Omega$
2). Outer conductor:	1.0 m $\Omega$
<i>Power handling (at 20 ° C, sea level, VSWR 1.0):</i>	$\leq 80 \text{ W @ } 2 \text{ GHz}$

### Environmental data:

<i>Temperature rating:</i>	-65 ° C to +165 ° C
<i>2002/95/EC (RoHS):</i>	Compliant

### Mechanical data:

<i>Mating cycles:</i>	$\geq 500$
<i>Center contact captivation:</i>	$\geq 15 \text{ N(axial)}$
<i>Coupling test torque:</i>	$\leq 1.7 \text{ Nm}$
<i>Recommended torque:</i>	0.46 Nm to 0.69 Nm

### Suitable cables:

RG174A/U, RG188A/U, RG316/U